

**FA54**

**FA74**

## Automatic pocket folding machines



The new generation, available in more than 13 versions – perfect technology and performance: For sheet formats of 54 x 80 cm and 74 x 104 cm.

Automatic settings make the machines easy to operate and they offer flat pile, round pile or pallet feeders (only with FA 74).

# GUK

## HOCHLEISTUNGS- FALZAUTOMATEN

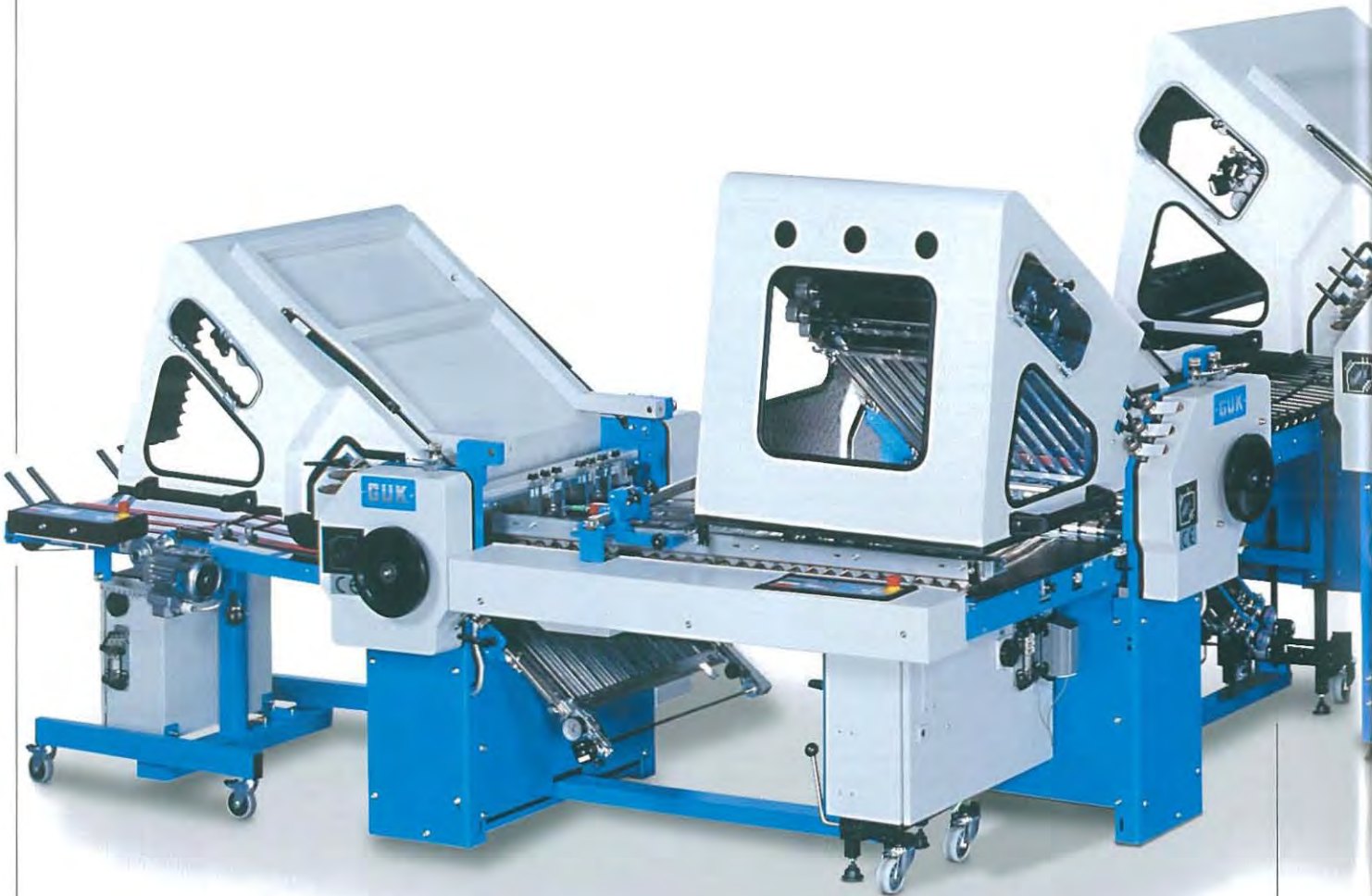

- New control features provided by L4 Control System and there is a large touchscreen display on the feeder.
- External operating panels with displays on all stations and the delivery.
- Central regulation of speed for all stations.
- Digital automatic sheet distance regulation.
- Option:
  - Automatic pocket setting with 99 programme memory slots.
  - Automatic setting-up mode.
- Automatic passage monitoring.
- Automatic fold length monitoring on each folding mechanism.
- No settings required due to new ultrasonic double sheet detector. If double sheets arise, the sheet transport is deactivated. The drive for the alignment table also stops. The double sheet can be removed and the machine processes the sheets which have entered the system in the meantime.
- A dual circuit system extracts the paper dust. The dust cannot therefore enter the suction mechanics but is instead extracted through a filter.
- Speed 200 m/min.



# FA 54 and FA 74

## Automatic pocket folding machines



- Double storing of folding rollers along with combined needle and thrust bearings guarantee smooth operations and total axial stability.
- Maintenance-free roller table drive on stations II and III.
- Chrome-plated transport rollers – dust-repellent and resistant to wear.
- Plug-in knife shafts in all stations.
- The tried and tested ZK 500 knife folding mechanism is used as the quadruple folding mechanism. A pressing and stacking station can also be fitted.
- The new pallet feeder guarantees reliable sheet separation and a maximum output of up to 30,000 cycles/hour.
- Synchronous folding roller drive delivered by spiral-toothed gears, which means that slip cannot occur – absolute synchronisation.



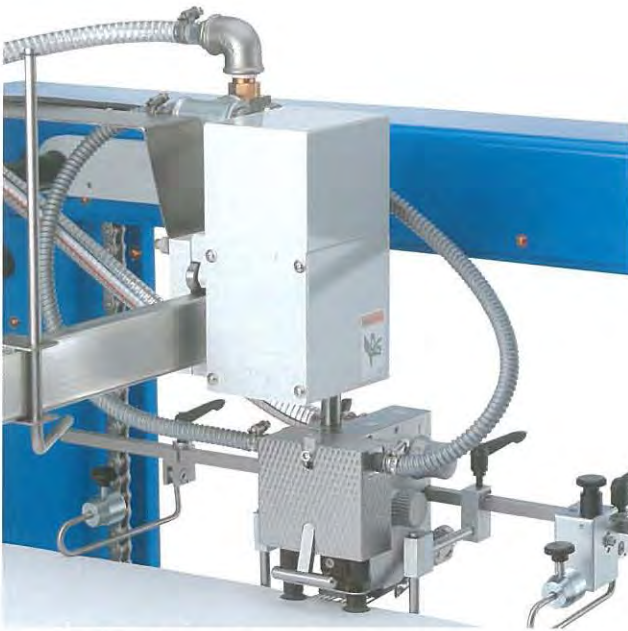

**Electronically controlled separator head with unique suction apparatus**

Facilitates exact sheet separation even at top performance speeds of more than 30,000 sheets per hour.

**Two-circuit system**

Consequently insensitive to dust.



**Rollers – automatic adjustment**

Simplest adjustment by means of paper strips. Additional precision micro-adjustment with an adjustable scale.

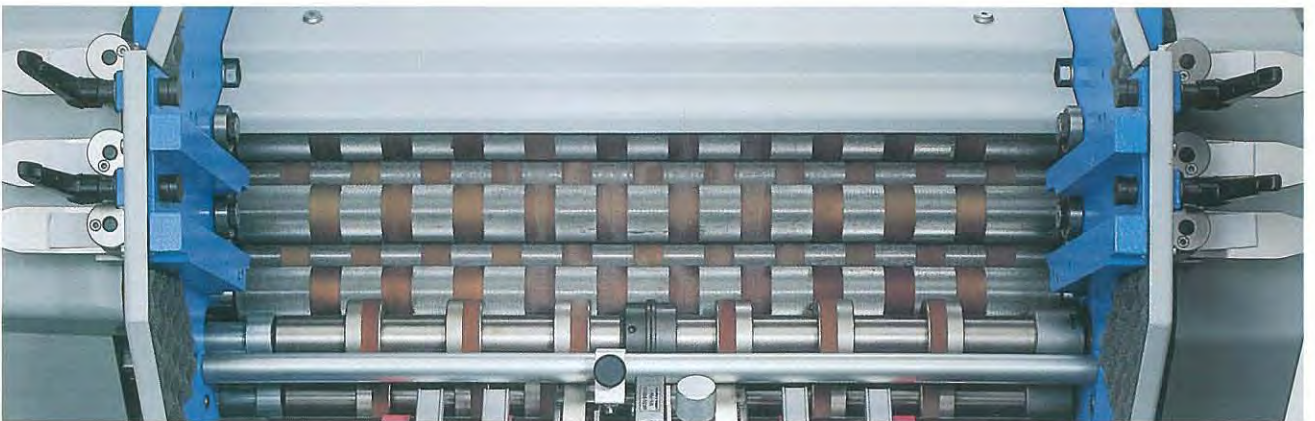

**A new generation of folding mechanisms**

Folding rollers with interchangeable plastic rings. Offset steel compartments which are self-cleaning. Optimal sheet guidance in continuous operation.

**Folding pocket fine adjustment with vernier adjuster**

Direct reading from all pockets, even on machines with noise-reducing encapsulation.

Fine adjustment for all adjustment elements. Integrated sheet shunts.

Simply set stop to 0, the sheet is then reversed.

Wear-resistant pocket intakes and guides.

Lubrication not possible since everything is hard anodised and made from Nirosta.





## Knife folding mechanism ZK 500

Electronically controlled knife folding mechanism. Adjustable for German and international quadruple folds.

Can also be connected to other manufacturers' machines such as collecting stitchers etc.

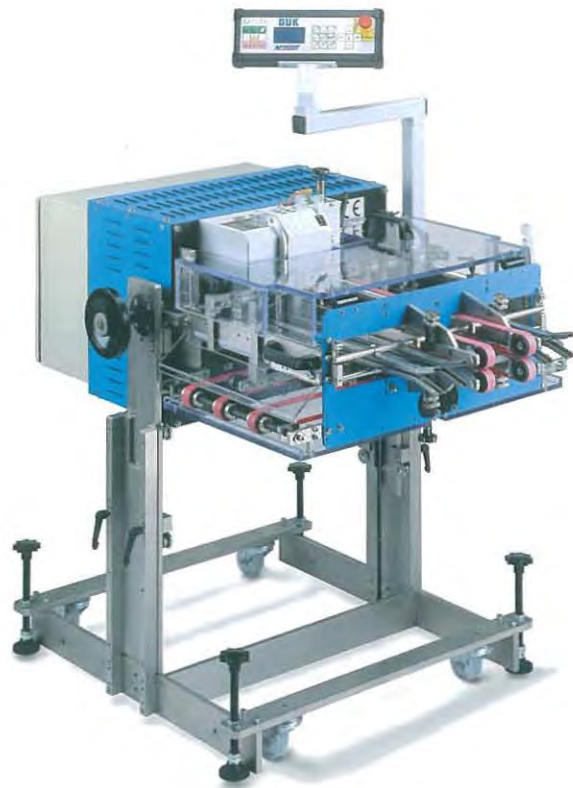

## FA 54 FA 74 in 12 models available

FA 74 selectively with flat pile feeder, round pile feeder or pallet feeder.

FA 54 selectively with flat pile feeder or round pile feeder.

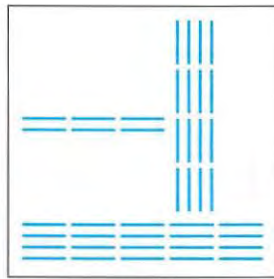

FA 54/4-4-2 K  
FA 74/4-4-2 K

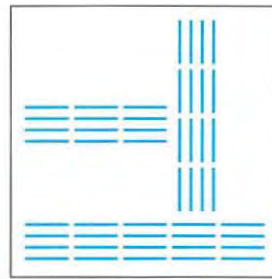

FA 54/4-4-4 K  
FA 74/4-4-4 K

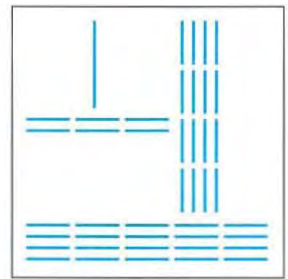

FA 54/4-4-2-1 K  
FA 74/4-4-2-1 K

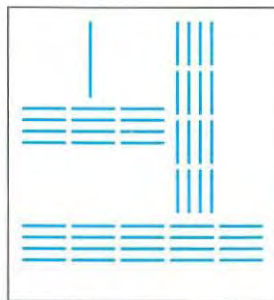

FA 54/4-4-4-1 K  
FA 74/4-4-4-1 K

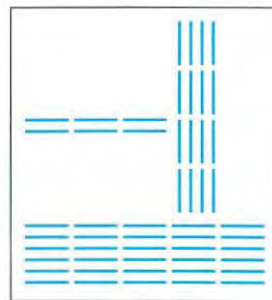

FA 54/6-4-2 K  
FA 74/6-4-2 K

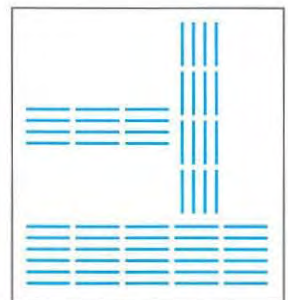

FA 54/6-4-4 K  
FA 74/6-4-4 K

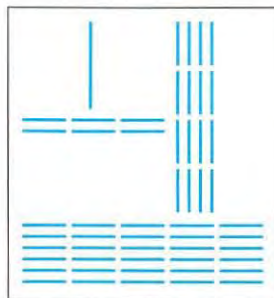

FA 54/6-4-2-1 K  
FA 74/6-4-2-1 K

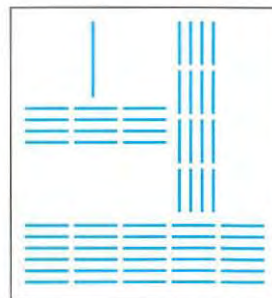

FA 54/6-4-4-1 K  
FA 74/6-4-4-1 K

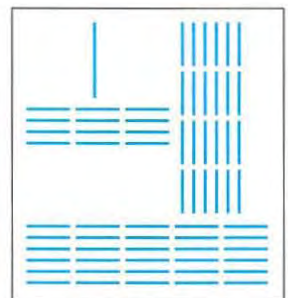

FA 54/6-6-4-1 K  
FA 74/6-6-4-1 K

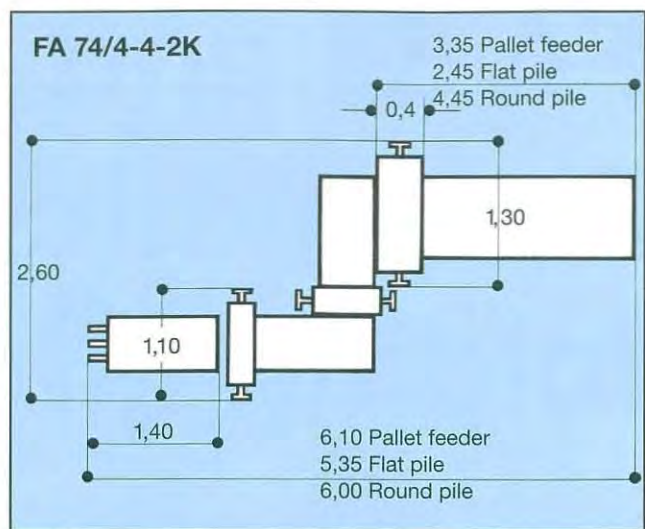
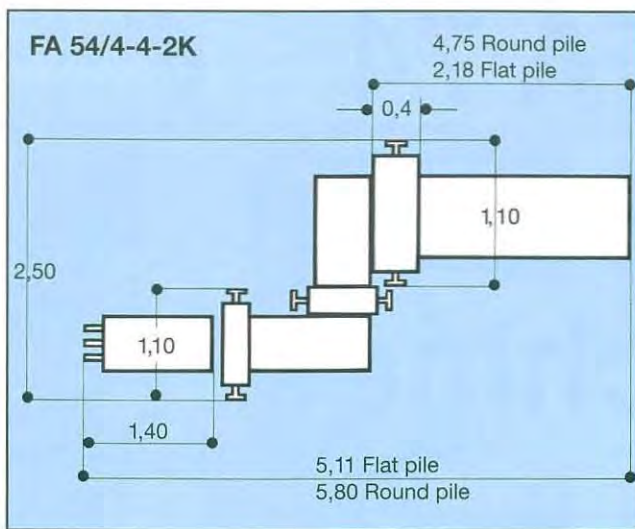

## Technical Data

Max. format:

### FA 54

Round pile feeder 54 x 144 cm  
Flat pile feeder 54 x 80 cm

### FA 74

Round pile feeder 74 x 144 cm  
Flat pile feeder 74 x 104 cm  
Pallet feeder 74 x 104 cm

Min. format:

Round pile feeder 16 x 16 cm  
Special design 12 x 16 cm  
Flat pile feeder 15 x 19 cm

Round pile feeder 16 x 21 cm  
Pallet feeder 21 x 30 cm  
Flat pile feeder 15 x 19 cm

Output:

30 – 200 m/min.  
bis 30 000 Bogen/h

30 – 200 m/min.  
up to 30,000 Bogen/h

Power requirement:

6 kW – 50 Hz

6 kW – 50 Hz

Weight:

Flat pile feeder 350 kg  
Round pile feeder 530 kg

Flat pile feeder 380 kg  
Round pile feeder 584 kg  
Pallet feeder 790 kg

Station I 388 kg  
Station II 440 kg  
Station III 374 kg  
Chute delivery S 520 42 kg  
Knife folding mechanism ZK 500 220 kg

Station I 414 kg  
Station II 440 kg  
Station III 374 kg  
Chute delivery S 720 49 kg  
Knife folding mechanism ZK 500 220 kg

## Special accessories

Batch-counter with output indicator  
Continuous counter  
Sound reduction hoods  
Glueing device  
Gate folding pocket  
Gathering device  
Crimping device  
Pressing and stacking unit  
Double stream device

## Our range

Automatic folding machines in passage widths of 21 – 30 – 35 – 36 – 43 – 45 – 49 – 54 – 74 cm. Over 80 models.

We also supply the pharmaceuticals and cosmetics industry with feeder systems and folding machines which work from the pile and from the roll.

Our range also includes folding machines manufactured to the customer's requirements – in

other words, not simply machines out of a catalog. Please consult us if you have a problem concerning folding. We are sure to have the right solution for you.

**GUK**  
HOCHLEISTUNGS-  
FALZAUTOMATEN

**GUK-Falzmaschinen**  
Griesser & Kunzmann GmbH & Co. KG

D-78669 Wellendingen · Bahnhofstraße 4  
Telefon (0 74 26) 703-1 · Telefax (0 74 26) 703-337  
info@GUK-Falzmaschinen.de · www.GUK-Falzmaschinen.de