



KBA Continent

Premier shaftless tower press
for 2/1 newspaper production



Technological excellence in every detail

First-rate 2/1 web press

The name reflects the aim: the KBA Continent is a sophisticated, user-friendly tower press targeting the global market and engineered for the production of top-quality colour newspapers and semi-commercials. A single-width press for four pages broadsheet or eight pages tabloid, the Continent is based on its hugely popular one-across/two-around stablemate, the Comet. It boasts technology that is second to none in this performance class, as evidenced by a string of awards and the admission of a Continent user in the Middle East to WAN-IFRA's elite Colour Quality Club.



The H-type printing units can be stacked to form a four-high tower for 4/4 blanket-to-blanket with one web or 2/2 with two webs. It is also possible to start off with 'incomplete' towers for 4/1 or 4/2 and to progress to a full colour capability in stages. DriveTronic shaftless drives and a modular construction with distributed controls support customised configurations to suit individual production specifications by allowing 'missing' couples to be added easily – and inexpensively – at any time.

The Continent has an above-average maximum web width of 1,000mm (39.37in) and the standard 533 - 700mm (21 - 27.5in) cut-off range customary in the international market. A maximum output of 75,000 copies per hour, cutting-edge console technology and a solid, ergonomic design for maximum ease of handling place the Continent at the very top of its class.

An extensive choice of optional equipment including dryers for full-colour semi-commercials and a facility for printing webs of different widths make the KBA Continent an attractive proposition for printers seeking a high degree of production flexibility. The Continent can be configured as a floor-mounted or two-floor version to suit presshall architecture.



Immaculate image

H-type printing units

The off-bearer H-type units on the Continent deliver a superb print quality, are freely accessible, easy to operate and need very little maintenance.

The robust, box-type side-frames eliminate vibration, even at high press speeds, and are engineered for a long service life. A patented configuration of zero-play multiring bearings ensures that the precision-engineered plate and blanket cylinders run smoothly. The plate cylinders are of corrosion-resistant refined steel, the blanket cylinders have a special abrasion-free, anti-corrosion coating. The main drives for the individual printing couples can double as auxiliary drives for plate mounting, pre-inking and washing, which saves time and eases operation.

Customised colour capability

The four-high tower version (two stacked H-type units) guarantees total flexibility in colour impositions. The Continent can print 4-over-4 on one web or 2-over-2 on two webs, with the option of additional web leads according to requirements. Straightforward webbing-up reduces down times during edition changes and enhances press reliability. If just the

upper printing couples in an H-type unit are to be used for a specific print run, an optional coupling is available that allows the web to be fed into the upper couples with no diversion.

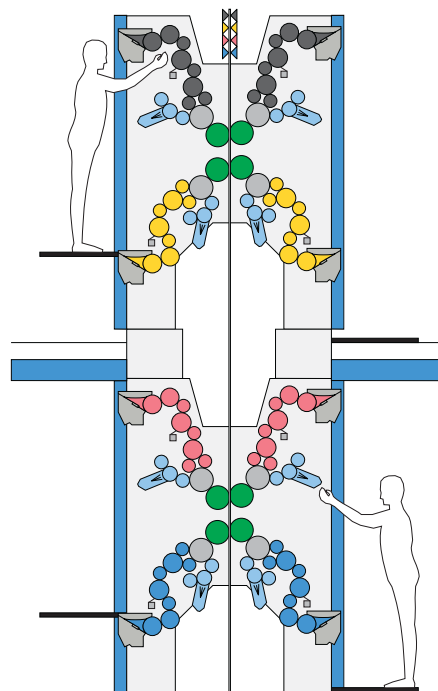

Quick and easy plate change

Maintenance-free lock-up slots and the ergonomic arrangement of the plate cylinders in the Continent promote quick and easy, register-true plate mounting without the need for tools. The slots are continuous so double-spread plates can be mounted. Circumferential and sidelay registration is remotely adjustable from the console.

Minigap on blanket cylinder

Proven minigaps and metal blankets guarantee an outstanding print quality while reducing maintenance and blanket-changing times. Provision is made for blanket-washing units.

Rigorous safety standards

The numerous safety features in the printing units conform to the most rigorous standards to protect both the press crew and machine aggregates.

Four-high tower of H-type printing units

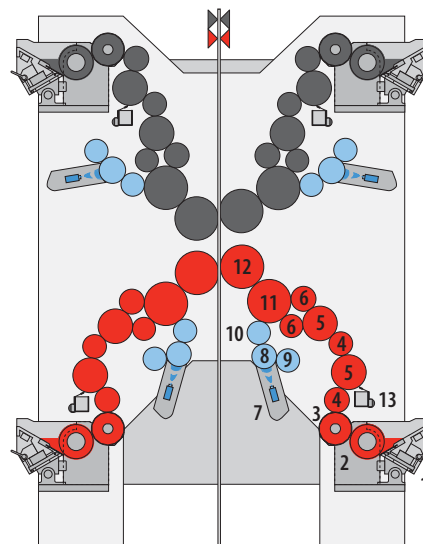
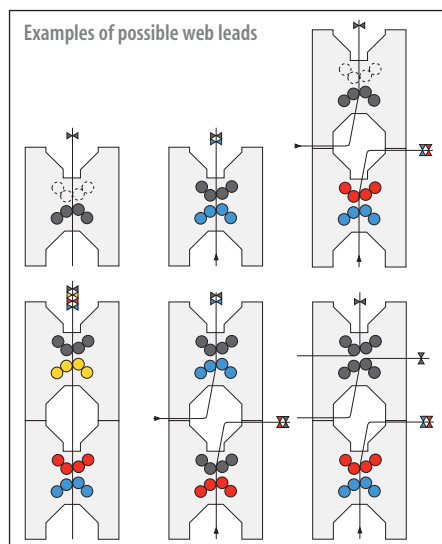

H-type printing unit

- 1 Ink duct
- 2 Duct roller
- 3 Film roller
- 4 Ink transfer roller
- 5 Distribution cylinder
- 6 Forme rollers
- 7 Spray bar
- 8 Chrome roller
- 9 Dampening roller
- 10 Plate dampener
- 11 Plate cylinder
- 12 Blanket cylinder
- 13 Roller washing unit

User-friendly

Film inking units and spray dampeners

The Continent incorporates proven film inking units with undershot ink knives for a brilliant full-colour print, plus low-maintenance three-roller spray dampeners.

Easy operation

The main components of the inking unit are the bleed-free segmented ink knives. The ink keys are adjusted remotely from the console, though manual adjustment directly at the ink duct is also possible.

The electrically driven duct roller and the superpolyamide-coated film roller transfer the ink film to the roller system. The duct-roller speed adapts to press speed by following a curve stored in the computer. As an option the oscillating distribution cylinder can be connected to a temperature control unit.

The washing system for the inking rollers, which is located at the distribution cylinder, is thrown on and off pneumatically and can be removed and inserted without the aid of tools. The ink forme rollers are also thrown on and off pneumatically and can be set with the finest precision.



Swivelling ink ducts facilitate ink changes

High-speed ink changes and cleaning

Inks can be changed quickly and easily using a set of tools that includes a wiper blade and an ink duct which can also be used to store ink. The ink ducts are thrown on and off pneumatically for cleaning. Inking units which can be disengaged and integrated in an automatic ink pumping system are available as an option.

Three-roller spray dampener

The fount solution is transferred to the dampener via a contactless, easy-access spray bar. The two individually controlled spray nozzles per broadsheet page (four across the web) ensure a precise metering of fount solution at all press speeds. Individual corrections can be made



The printing units are designed for ergonomic operation

remotely from the console. The contact-free transfer of fount solution eliminates contamination and reduces maintenance. A dampening feed unit is installed for each press section to filter, prepare and cool the solution. Shutters limit dampening application on narrower webs.

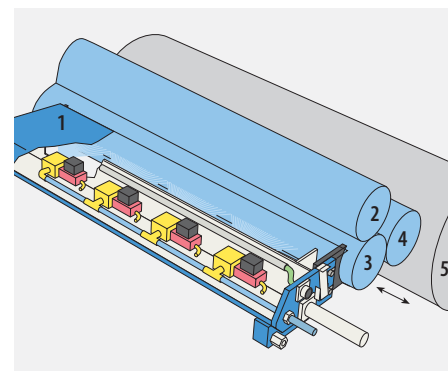

Three-roller spray dampener

- 1 Spray bar with 4 nozzles
- 2 Dampening roller
- 3 Chrome roller
- 4 Plate dampener
- 5 Plate cylinder





Correct web tension

KBA Basko

A problem-free web run and a uniform web tension were the engineering objectives specified for the Continent to ensure consistent, reliable operation and low waste levels.

Web infeed

The web is fed in via a running belt that guides it from the reelstand to the RTF. The continuous belt system feeds the web in fast, is reliable, easy to operate and requires a minimum of maintenance. Each belt can be used for two different web leads. An optional chain web-up system is available to feed the web through the dryer for semi-commercial production.

Safe web run

Low-mass, smooth-running idler rollers promote a problem-free web run during changes in press speed. The rollers that come into contact with the freshly printed web are shot-blasted and hard chromium-plated. Photoelectric sensors monitor the web right up to the delivery fan and trigger the appropriate safety measures in the event of a web break. Adjustable registration units in the plate cylinder, plus web aligners between the H-type units in a four-high tower, compensate for fan-out.

Infeed units

The infeed units in front of the printing units are each controlled by a reliable, rapid-response measuring roller and driven by an AC motor acting directly on the draw roller. To reduce slip the web is pressed against the draw roller by trolleys.

Left: A uniform web tension promotes a high print quality and low waste rate



KBA Basko

Our web-tension control system, Basko, furnishes the press operator with an effective tool for presetting, monitoring and maintaining the correct web tension. The standard tension is set at the reelstand and console and the actual tension throughout the press is indicated on the console screen as an easy-to-read display, allowing rapid intervention by the operator. There is a measuring point between each infeed unit and subsequent printing unit. The adjustable infeed units in front of the printing units, and the draw rollers in the superstructure, allow the operator to set the optimum tension for each web individually prior to the production run.

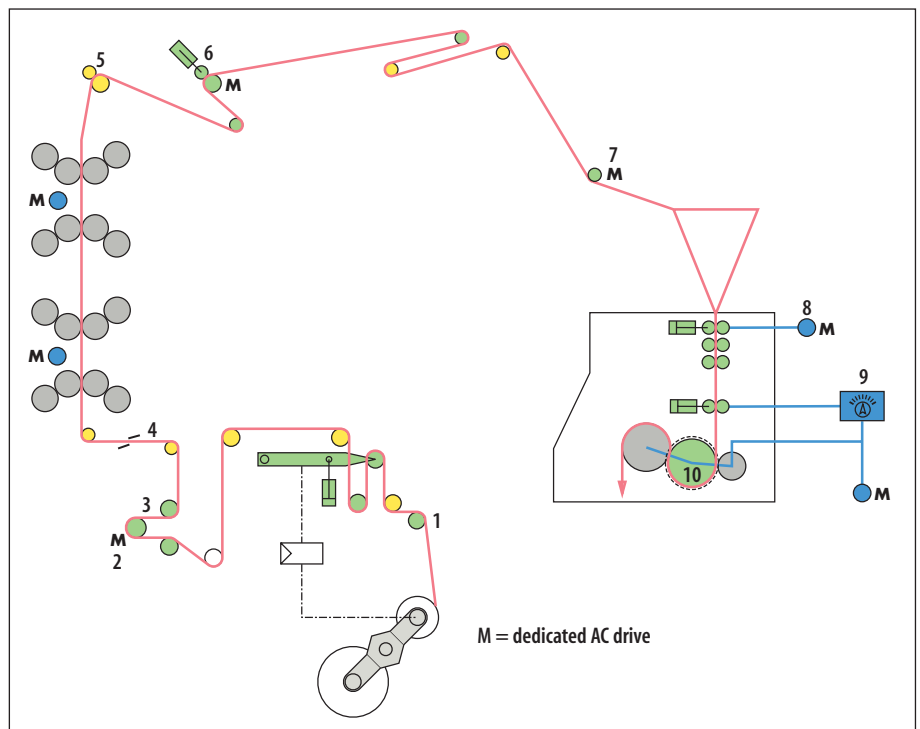

Basko web-tension control system

- | | |
|--|--|
| 1 Basic tension, can be set at the reelstand and console | 7 AC motor for the ribbon-gathering roller and RTF |
| 2 Infeed unit with AC drive | 8 AC motor for the draw rollers beneath the former |
| 3 Measuring point | 9 Variable-speed gearing for the main draw rollers in the folder |
| 4 Severer | 10 Diameter enlarger for the pin cylinder |
| 5 Photoelectric sensor | |
| 6 AC motor for the draw roller in the superstructure | |



Product flexibility

Customised superstructure configurations

The compact yet sturdy superstructure on the Continent is freely accessible for makeready tasks and is easy to operate. A wide array of optional features affords exceptional flexibility.

Simple operation

The arrangement of the draw rollers and idling rollers – one for each web – helps minimise makeready times. The web is aligned by electrically driven draw rollers and a motorised cut-off register adjustment unit. Draw-roller advance and the register position are infinitely adjustable from the console. The specified values are displayed as a graph on the screen, with program-controlled repositioning of the cut-off register during changes in speed.

Raft of options

The configuration of the rollers and turner bars in the superstructure supports a variety of ribbon insertions.

For even greater production flexibility the superstructure on the Continent can be equipped with optional turner bars (with or without bay windows), an insertion deck etc.

Folder superstructure

The electrically driven RTF that gathers the individual ribbons has trolleys with pneumatic thrown-on/off plus a slitter for tabloids. The air-blown 71° former creates a precise length fold before the ribbons enter the folder. RTF advance can be remotely adjusted and controlled from the console. The folding rollers can be set separately on both sides to the specified copy thickness. Their angle of inclination can also be adjusted in order to avoid creasing the copies.

The Continent is normally configured with one former in the folder superstructure. To accommodate individual production requirements we also offer the option of two or three balloon formers, a skip slitter, section stitcher, length and/or cross perforator, length gluing unit etc



Left: The web running into the folder via the former, viewed from the dedicated AC drives for the draw rollers in the superstructure

Right: View of the superstructure on a Continent

Accuracy and dependability

KF 3B and KF 3 jaw folders

The Continent is available with a choice of two state-of-the-art folders: the standard KF 3B or the more highly automated KF 3. Both have a 2:3:3 cylinder ratio, the same dimensions and compatible interfaces, and both can deliver a maximum of 64 pages broadsheet or 128 pages tabloid.

The two folders incorporate extensive safety features and are engineered for durability. Maintenance- and user-friendly, they are extremely reliable and deliver a razor-sharp fold. They are also fully embedded in the DriveTronic shaftless drive system and have dedicated AC drives that can double as auxiliary drives for makeready and maintenance tasks.

KF 3B jaw folder

The speed and advance of the main draw rollers in the KF 3B can be controlled either directly at the folder or from the console, and are integrated in the Continent's shaftless drive and presetting system. Jaw gap, overfold and underfold can all be adjusted centrally at the folder during makeready. The diameter of the pin cylinder is infinitely adjustable to page count at the folder during the production run. Copy spacing in the delivery stream is also adjustable. If the web jams, an electronic copy control in the paddle wheel actuates the severing knife, which together with an electronic overload protection device in the drive motor brings the press to an immediate halt. To ensure a smooth machine run, the folding-cylinder assembly and the delivery are located in the same rigid cast-iron substructure.

The KF 3B jaw folder combines rugged technology and intelligent automation with value for money



KF 3 jaw folder

The KF 3 folder is extensively automated for faster conversion of production-relevant functions. The diameter of the pin cylinder can be infinitely adjusted pneumatically at the folder or the console to accommodate the specified copy thickness. Over- and underfold adjustments can be carried out remotely at the console while the press is running. An electronic copy control with counter is located between the jaw cylinder and the delivery wheel.

Optional extras for greater flexibility

For even greater flexibility the KF 3 folder can be fitted with various optional features, eg a quarterfold facility as a chopper fold, a second parallel cross fold, cross and length perforators, ribbon and section stitchers and gluing and/or softening units.

Right: The high-performance KF 3 folder is highly automated yet easy to access

KBA KF 3B jaw folder (with extras)

- 1 Former
- 2 Driven draw rollers
- 3 Length perforator (optional)
- 4 Cross perforator (optional)
- 5 Draw-roller motor
- 6 AC drive
- 7 Section stitcher (optional)
- 8 2:3:3 cylinder assembly
- 9 Quarterfold (optional)

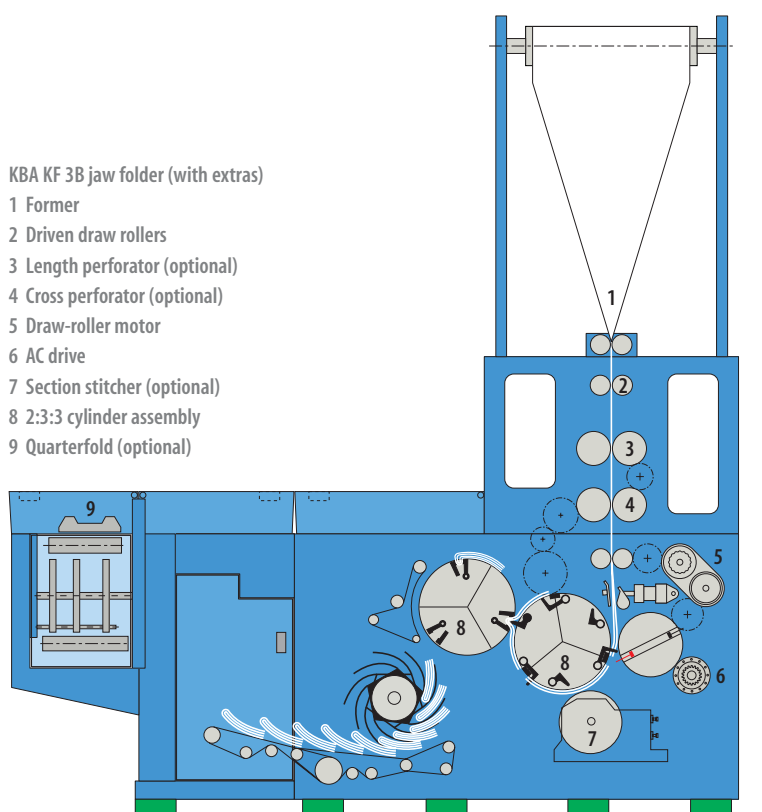



Just-in-time reel supply

Efficient logistics

Like all KBA web presses the Continent can be embedded in a KBA Patras reel-logistics system. The standard reelstand is a Pastoline.

KBA Patras reel-logistics system

The KBA Patras paper transport system (see separate brochure) is module-based to support a wide range of versions, eg with transfer table, rails and reel truck, so that it can be customised to accommodate individual production specifications and plant architecture.

KBA Pastoline reelstand

The Pastoline automated reelstand has AC drives, an electric braking system, split arms and an operator-friendly design. It is built for web speeds of up to 13mps (2,560fpm). The arms on the standard version can handle a variety of web widths in increments of 1mm (0.04in) up to a maximum of 1,000mm (39.37in), a maximum web width of 1,270mm (50in) and a maximum reel weight of 1.3 tonnes (2,866lbs). Pastoline reelstands are fully integrated in the console system and exceptionally easy to operate. Optional extras, eg lateral alignment of the outer reel edges to the expiring web, are available for semi-commercial production.



Top: The Patras reel-handling system supports logistical flexibility

Right: The Pastoline reelstand is reliable, cost-effective and can handle a range of reel widths





Intelligent automation

Modular system

Cutting-edge console technology, distributed controls at subassembly level and a host of optional automation modules allow the Continent to be custom-configured to suit individual specifications.

Three-level hierarchy

- Subassembly level with distributed controls
- Console level with operating and data systems
- Process level with production management system (optional)

Distributed controls

The reelstands, printing units, folders and other subassemblies are controlled via distributed processing stations linked to each other and to the console by high-powered data bus systems. Control panels directly at the printing units and folders, and a mobile, plug-in control station for all offset functions make for easier operation.

Console level

The production run is controlled via automated press functions initiated, controlled and monitored from ergonomically designed, height-adjustable consoles featuring process-oriented graphical user interfaces and clear, colour data screens.

Left: The print run is monitored and controlled from high-tech consoles



With the Continent the page(s) on which changes are to be made can be selected directly by using presetting data (product-oriented job preparation and press operation). As an alternative, production can be press-oriented, ie the subassembly requiring adjustment is selected via the function keyboard with the aid of informative colour graphic screens. Depending on the press configuration the main data screens are augmented by auxiliary screens for additional aggregates.

With the relevant modules a large volume of production data for repeat jobs can be stored at the console without the need for an additional production scheduling and presetting system.

Link-up to production management system

The console system can, as an option, be linked to a production scheduling and press presetting system and/or expanded to include additional modules, eg for maintenance, statistics etc. Digital data for presetting the ink keys can be downloaded online from pre-press via a RIP interface. In addition, data can be exchanged directly with other company departments such as administration and/or sales.

Remote maintenance and diagnostics

An optional remote diagnostics PC with VPN router furnishes a direct link to the KBA service department.



Suitable for semi-commercials

Heatset package

The Continent is a popular choice for semi-commercial (heatset) production on improved stock and delivers a high-quality print, especially on matt-coated, SC and LWC stock, at a very favourable cost per copy.

High level of cost efficiency

More and more printers are specifying thermal air dryers and the associated heatset facilities so that they can print supplements and other semi-commercials such as ad inserts, flyers etc alongside their standard newspaper titles. This is a field in which we have a wealth of experience – and a large installed base.

Heatset package

Depending on the job to be printed the special version recommended for printing quality semi-commercials can include the following features:

- reinforced inking units
- ink temperature control
- porcupine roller with web catcher
- hot-air dryer
- chill roller stand
- silicone unit
- sidelay control
- stitchers
- gluing units

- length and cross perforators
- quarterfold and/or second parallel cross fold etc.

Two essentials for a good print quality are, of course, an efficient pre-press and the use of high-grade consumables (ink, paper etc).

Top: Chill-roller stand after the heatset dryer

KBA Continent

At a glance

Specifications	
Standard formats:	KBA Pastoline reelstand
Maximum web width: 870/1,000 mm (34.25/39.37 in)	Maximum reel diameter: 1,270 mm (50 in)
Cylinder circumferences: 533 - 700 mm (21 - 27.5 in)	Maximum splicing speed: 13 mps (2,560 fpm)
Maximum output: 75,000 cph (depending on format and equipment)	KBA Patras reel logistics With choice of automation levels
Printing units:	KBA KF 3B and KF 3 folders
• H-type, partial or complete, 2 - 4 couples	2:3:3 cylinder ratio
• Stacked H-type, maximum 8 couples	Maximum output: 64 broadsheet or 128 tabloid pages
• Film inking units with undershot ink knives	
• 3-roller spray dampening units	
Shaftless drives:	
KBA DriveTronic with dedicated AC drives	
Option:	
Semi-commercial package with thermal air dryer	



Modifications may be made with no prior notice. No part of this publication may be reproduced in any way without the permission of Koenig & Bauer AG. Illustrations may depict special features not included in the basic press price.

**The KBA Continent from
Koenig & Bauer AG**

For further information please contact
our sales department at:
Koenig & Bauer AG
Würzburg Facility
Postfach 60 60
97010 Würzburg, Germany
Friedrich-Koenig-Str. 4
97080 Würzburg, Germany
Tel: (+49) 931 909-0
Fax: (+49) 931 909-4101
kba-wuerzburg@kba.com
www.kba.com
10/2010-e. Printed in Germany

Our agency:

